

HA 系列
SERIES

85°C 長壽命品
壽命：85°C 3000 小時

85°C LONG LIFE
Load Life :85°C 3000 hours

■ 規格表 SPECIFICATIONS

項目 Items	特性 Characteristics														
使用溫度範圍 Category Temperature Range	-40~+85°C							-25~+85°C							
額定電壓範圍 Rated Voltage Range	10~100V.DC							160~450V.DC							
靜電容量容許差 Capacitance Tolerance	±20%(M)(25°C, 120Hz)														
洩漏電流 Leakage Current (MAX)	I ≤ 0.03CV (施加額定電壓 5 分鐘後) (After 5 minutes application of rated voltage) I : 洩漏電流 Leakage Current(μA) C : 額定靜電容量 Rated Capacitance(μF) V : 額定電壓 Rated Voltage(V)														
散逸因素(tan δ) Dissipation Factor (MAX)	額定電壓(V) Rated Voltage	10	16	25	35	50	63	100	160~250	350~450	120Hz				
	tan δ	CV ≤ 100,000	0.50	0.40	0.35	0.25	0.25	0.25	0.20	0.20	0.25	25°C			
高溫負荷 Load Life	85°C 恆溫施加額定電壓(含紋波電流)3000 小時後，必須滿足下列的值。 After applying rated voltage with rated ripple current for 3000hrs at 85°C, the capacitors shall meet the following requirements														
	靜電容量變化率 Capacitance Change	初期值±25%以內 Within ±25% of the initial value													
	散逸因素(tan δ) Dissipation Factor	規格值 150%以下 Not more than 150% of the specified value													
	洩漏電流 Leakage Current	規格值以下 Not more than the specified value													
高溫放置 Shelf Life	85°C 恆溫不施加額定電壓 1000 小時後，必須滿足下列的值。 After applying no rated voltage for 1000hrs at 85°C. The capacitors shall meet the following requirements.														
	靜電容量變化率 Capacitance Change	初期值±20%以內 Within ±20% of the initial value													
	散逸因素(tan δ) Dissipation Factor	規格值 150%以下 Not more than 150% of the specified value													
	洩漏電流 Leakage Current	規格值 150%以下 Not more than 150% of the specified value													
突波電壓(V) Surge Voltage	額定電壓(V) Rated Voltage	10	16	25	35	50	63	100	160	200	250	350	400	450	
	突波電壓(V) Surge Voltage	13	20	32	44	63	79	125	200	250	300	400	450	500	
低溫特性 Low Temperature Stability (合成阻抗比) Impedance Ratio (MAX)	額定電壓(V) Rated Voltage	10~100				160~250				350~450				120Hz	
	Z(-25°C) / Z(25°C)	4				6				8					
	Z(-40°C) / Z(25°C)	15				-				-					

■ 尺寸圖 DIMENSIONS

(mm)

■ 紋波電流補償係數 MULTIPLIER FOR RIPPLE CURRENT

(1) 頻率係數 Frequency coefficient

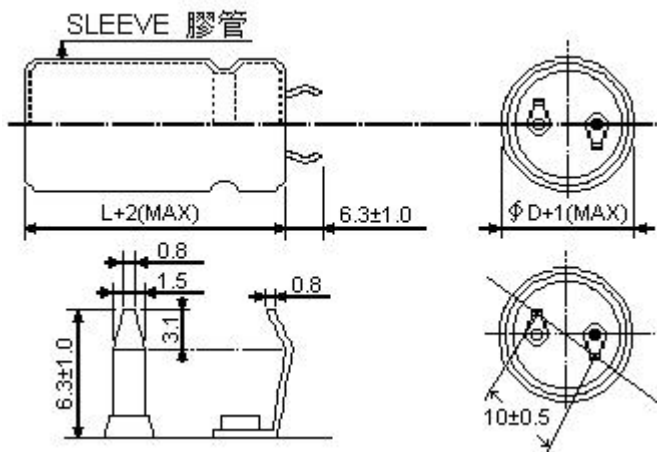

頻率(Hz) Frequency		60	120	1k	10k	100k
係數 Coefficient	10~35V	0.90	1.00	1.05	1.10	1.10
	50~100V	0.90	1.00	1.15	1.20	1.20
	160~250V	0.80	1.00	1.35	1.45	1.50
	350~450V	0.80	1.00	1.10	1.15	1.20

■ 尺寸一覽表，額定紋波電流一覽表 STANDARD SIZE, RATED RIPPLE CURRENT

Size ϕ D×L(mm), Ripple Current (A r.m.s./85°C, 120 Hz)

額定電壓 WV(V.DC) 額定 靜電容量 Cap(μF)	10 (1A)								額定電壓 WV(V.DC) 額定 靜電容量 Cap(μF)	16 (1C)							
	ϕ 22		ϕ 25		ϕ 30		ϕ 35			ϕ 22		ϕ 25		ϕ 30		ϕ 35	
	Size	Ripple	Size	Ripple	Size	Ripple	Size	Ripple		Size	Ripple	Size	Ripple	Size	Ripple	Size	Ripple
15000	22×25	3.10							10000	22×25	2.70						
18000	22×30	3.40	25×25	3.40					15000	22×30	3.35	25×25	3.35				
27000	22×40	4.50	25×30	4.50					18000	22×40	4.40	25×30	4.15				
33000	22×45	4.95	25×35	4.95					22000	22×45	4.85	25×35	4.85	30×25	4.60		
39000	22×50	5.30	25×40	5.30	30×30	5.30			27000	22×50	5.25	25×40	5.25	30×30	5.25		
47000			25×45	5.90	30×35	6.00			33000			25×45	5.75	30×35	5.75		
56000			25×50	6.15	30×40	6.25	35×30	6.10	47000					30×40	6.20	35×35	6.40
82000					30×50	7.25	35×40	7.25	56000					30×50	7.05	35×40	7.05
100000							35×45	7.75	82000							35×50	8.15

額定電壓 WV(V.DC) 額定 靜電容量 Cap(μF)	25 (1E)								額定電壓 WV(V.DC) 額定 靜電容量 Cap(μF)	35 (1V)							
	ϕ 22		ϕ 25		ϕ 30		ϕ 35			ϕ 22		ϕ 25		ϕ 30		ϕ 35	
	Size	Ripple	Size	Ripple	Size	Ripple	Size	Ripple		Size	Ripple	Size	Ripple	Size	Ripple	Size	Ripple
6800	22×25	2.45							3900	22×25	2.45						
8200	22×30	3.05	25×25	3.05					5600	22×30	3.05						
10000	22×35	3.50	25×30	3.50					6800	22×35	3.45						
15000	22×45	4.35	25×35	4.35					8200	22×40	3.80						
18000	22×50	4.70	25×40	4.70	30×30	4.70	35×25	4.70	12000	22×50	4.65	25×40	4.65				
22000			25×50	5.65	30×35	5.35	35×30	5.65	15000			25×50	5.50	30×35	5.30	35×30	5.50
27000					30×40	5.75	35×35	6.05	18000					30×40	5.60	35×35	5.90
39000					30×50	6.55	35×40	6.55	22000					30×50	6.55	35×40	6.55
47000							35×50	7.90	27000							35×45	7.40
									33000							35×50	7.90

額定電壓 WV(V.DC) 額定 靜電容量 Cap(μF)	50 (1H)								額定電壓 WV(V.DC) 額定 靜電容量 Cap(μF)	63 (1J)							
	ϕ 22		ϕ 25		ϕ 30		ϕ 35			ϕ 22		ϕ 25		ϕ 30		ϕ 35	
	Size	Ripple	Size	Ripple	Size	Ripple	Size	Ripple		Size	Ripple	Size	Ripple	Size	Ripple	Size	Ripple
2200	22×25	2.45							1500	22×25	1.90						
3300	22×30	3.10							2200	22×30	2.40	25×25	2.50				
3900	22×35	3.40							2700	22×35	3.10	25×30	3.10				
4700	22×40	3.85	25×30	3.85					3900	22×45	4.05	25×35	4.05				
6800	22×50	4.65	25×40	4.75	30×30	4.75			4700			25×40	4.40	30×30	4.40	35×25	4.40
8200			25×45	5.15	30×35	5.15			5600					30×35	4.90	35×30	4.90
10000					30×40	5.55	35×30	5.35	8200							35×35	5.90
15000					30×50	6.50	35×40	6.50	12000							35×50	7.55
18000							35×45	7.30									
22000							35×50	7.85									

額定電壓 WV(V.DC) 額定 靜電容量 Cap(μF)	100 (2A)								額定電壓 WV(V.DC) 額定 靜電容量 Cap(μF)	160 (2C)							
	ϕ 22		ϕ 25		ϕ 30		ϕ 35			ϕ 22		ϕ 25		ϕ 30		ϕ 35	
	Size	Ripple	Size	Ripple	Size	Ripple	Size	Ripple		Size	Ripple	Size	Ripple	Size	Ripple	Size	Ripple
680	22×25	1.40							270	22×25	0.90						
820	22×30	1.65							390	22×30	1.10						
1000	22×35	1.90	25×25	1.90					470	22×35	1.30	25×25	1.20				
1200	22×40	2.10	25×30	2.10					560	22×40	1.50	25×30	1.50				
1500	22×45	2.65	25×35	2.65					680	22×45	1.70	25×35	1.70				
1800	22×50	2.95	25×40	2.95	30×30	2.95			820	22×50	2.00	25×40	2.00	30×30	2.00	35×25	2.00
2200			25×45	3.45	30×35	3.45			1000			25×45	2.30	30×35	2.30	35×30	2.30
2700			25×50	3.95	30×40	3.95	35×30	3.95	1200					30×40	2.63	35×35	2.63
3300					30×45	4.45	35×35	4.45	1800					30×50	3.30	35×45	3.60
3900					30×50	4.95	35×40	4.95	2200							35×50	4.25
4700							35×45	5.50									
5600							35×50	6.00									

■ 尺寸一覽表，額定紋波電流一覽表 STANDARD SIZE, RATED RIPPLE CURRENT

Size ϕ D \times L(mm), Ripple Current (A r.m.s./85°C, 120 Hz)

額定電壓 WV(V.DC)	200 (2D)								額定電壓 WV(V.DC)	250 (2E)							
	ϕ 22		ϕ 25		ϕ 30		ϕ 35			ϕ 22		ϕ 25		ϕ 30		ϕ 35	
	Size	Ripple	Size	Ripple	Size	Ripple	Size	Ripple		Size	Ripple	Size	Ripple	Size	Ripple	Size	Ripple
220	22 \times 25	0.90							150	22 \times 25	0.73						
330	22 \times 30	1.10							220	22 \times 30	1.00	25 \times 25	0.93				
390	22 \times 35	1.30							330	22 \times 40	1.25	25 \times 30	1.25				
470	22 \times 40	1.50	25 \times 30	1.50					390	22 \times 45	1.45	25 \times 35	1.45				
560	22 \times 45	1.70	25 \times 35	1.70	30 \times 25	1.60			470	22 \times 50	1.70	25 \times 40	1.70	30 \times 30	1.70		
680	22 \times 50	2.00	25 \times 40	2.00	30 \times 30	2.00	35 \times 25	2.00	560			25 \times 45	1.95	30 \times 35	1.95		
1000			25 \times 50	2.58	30 \times 40	2.58	35 \times 30	2.43	680			25 \times 50	2.15	30 \times 40	2.15	35 \times 30	2.15
1500					30 \times 50	3.25	35 \times 40	3.25	820					30 \times 45	2.50	35 \times 35	2.50
1800							35 \times 50	4.20	1200							35 \times 50	3.45

額定電壓 WV(V.DC)	350 (2V)								額定電壓 WV(V.DC)	400 (2G)							
	ϕ 22		ϕ 25		ϕ 30		ϕ 35			ϕ 22		ϕ 25		ϕ 30		ϕ 35	
	Size	Ripple	Size	Ripple	Size	Ripple	Size	Ripple		Size	Ripple	Size	Ripple	Size	Ripple	Size	Ripple
100	22 \times 25	0.45							100	22 \times 25	0.45						
150	22 \times 35	0.75	25 \times 25	0.70					150	22 \times 35	0.68	25 \times 25	0.68				
180	22 \times 40	0.85	25 \times 30	0.80					180	22 \times 40	0.80	25 \times 30	0.80				
220	22 \times 45	1.00	25 \times 35	1.00	30 \times 25	0.93			220	22 \times 45	0.95	25 \times 35	0.95	30 \times 25	0.95		
270	22 \times 50	1.13	25 \times 40	1.13	30 \times 30	1.13	35 \times 25	1.13	270	22 \times 50	1.05	25 \times 40	1.05	30 \times 30	1.05		
390			25 \times 50	1.50	30 \times 40	1.50	35 \times 30	1.40	330			25 \times 45	1.20	30 \times 35	1.20		
470					30 \times 45	1.70	35 \times 35	1.70	390			25 \times 50	1.40	30 \times 40	1.40	35 \times 30	1.40
560					30 \times 50	2.00	35 \times 40	2.00	470					30 \times 45	1.63	35 \times 35	1.63
820							35 \times 50	2.95	560					30 \times 50	1.85	35 \times 40	1.85
									680							35 \times 45	2.08
									820							35 \times 50	2.53

額定電壓 WV(V.DC)	450 (2W)							
	ϕ 22		ϕ 25		ϕ 30		ϕ 35	
	Size	Ripple	Size	Ripple	Size	Ripple	Size	Ripple
82	22 \times 25	0.42						
100	22 \times 30	0.78	25 \times 25	0.55				
150	22 \times 40	0.75	25 \times 30	0.75				
180	22 \times 50	0.95	25 \times 35	0.90				
220			25 \times 40	0.98	30 \times 30	0.98	35 \times 25	0.98
270			25 \times 50	1.28	30 \times 35	1.20	35 \times 30	1.28
390					30 \times 45	1.53	35 \times 35	1.53
470					30 \times 50	1.73	35 \times 40	1.73
560							35 \times 50	2.25